



BRITISH
ENCODER
PRODUCTS COMPANY



Equipment like yours...



**Deserves quality
like ours.**

BEPC combines advanced optics and sensor technology with intelligently engineered housings for performance you and your customers can rely on. Made in the United Kingdom and backed by our industry-best three year warranty, British Encoder Products Company rotary encoders deliver when it counts—which is all the time.



Short-form Brochure

The Responsive People In Motion Control



**BRITISH
ENCODER**
PRODUCTS COMPANY



Company History

British Encoder Products is the European branch of Encoder Products Company Inc (EPC). EPC is a leading designer and world-wide manufacturer of motion sensing devices. Founded in 1969 by William Watt, EPC began operations with a small line of custom encoders. Today, more than 40 years later, EPC's popular Accu-Coder™ brand is the most complete line of incremental and absolute shaft encoders in the industry. Our core philosophy is that each and every customer deserves quality products, superior customer service, and expert support.

Business Partnerships

Fostering long term business partnerships with satisfied customers is what we do best, and the heart of our mission. We take pride in providing superior customer service and supplying you an encoder that functions precisely, dependably, and flawlessly. Listening to our customers needs, and designing products that provide solutions for them, is a key to our success. It isn't every company that can say they have satisfied their customers for over 40 years!

Solving Problems

For over 40 years, we have been solving encoder problems. Custom designs, faster delivery, and reliable products are all areas in which we excel. We believe that an encoder supplier should solve problems, not cause them.

Innovative Design Team

At EPC, we concentrate on encoders, making us famous for paving the path of the encoder industry and providing encoder standards for our industry since 1969. First to design the cube style encoder, now an industry standard. First to resolve mounting installation problems by providing an industry first flexible-mounting system. First to include Opto-ASIC technology, which virtually eliminates miscounts by removing electrical noise, and enhancing signal quality. First to provide an encoder that operates at 120° C. First to provide 6000 PPR in a 38mm diameter encoder. First to provide a 3 year standard warranty, demonstrating that we stand proudly behind the reliability of each of our products.

Custom Encoders Our Specialty

Through years of experience, we understand each industrial environment is different; you need an encoder that fits your specific situation. This ultimately means not having to make do with someone else's specifications or configurations, but having your own custom designed unit. Many of our customers have come to depend on us for this special area of customization. Using state of the art technology, we can design and deliver custom encoders faster than most suppliers standard products - often shipping your unique encoder in 2 to 6 days or sooner.

Electro Magnetic Compatibility, EC Directive 89/336/EC

All of our products have been certified by an independent test house to ensure that each type will fully integrate into systems or machines requiring EMC certification.

Since Jan 1996, Encoders fitted with a flying lead have the cable screen in contact with the encoder frame. The purpose of this is to ensure total shielding of the encoder electronics by virtue of its metallic body and cover, all of which will be bonded together and terminated to the screen.

The user should ensure that the component parts of the machine, or system frame, are at the same potential (frame/ground/earth/signal ground/pe), if necessary, by bonding together by means of a copper "equi-potential bonding conductor" of at least 6mm section to the P.E. (building protective earth).

For Encoders fitted with a connector, wherever possible, we will fit a "case ground" to one of the connector pins; this will be in contact with the encoder frame.

RS422 differential drive should be employed wherever possible. Always use sensible cabling practice by separating encoder signal cable routing from other devices, if necessary, by use of grounded separators or trunking. Use twisted pair cables with an overall braided screen, e.g. BELDEN 9807 or equivalent.

The RXTXD module can help to solve most problems when transmitting encoder signals over long lengths of cable.

ISO 9001 Quality Systems

At BEPC, quality is designed into every product. Before it's offered for sale, each Encoder model is developed using state-of-the-art design tools and fully tested against BEPC's exacting quality standards. But quality does not stop at design. During the manufacturing process, each Encoder is subjected to a series of stringent quality control tests to ensure you are receiving the best encoder available. Our quality system has successfully been audited to the requirements of ISO 9001:2008, an internationally recognized standard for comprehensive Quality Systems. By paying close attention to detail, our Encoder brand has become known throughout the industry for quality and reliability.

BS OHSAS 18001:2007

British Encoder Products are committed to maintaining a safe and caring work place. In order to demonstrate our commitment to this we have had our health and safety procedures and systems audited and approved to BS OHSAS 18001:2007. We believe this benefits our customers due to our employees producing higher quality products with less wastage and rework necessary.

The British Encoder Products Advantage!



Superior Design



- First To Use Opto-ASIC Technology
- Creators Of The First Cube Encoder
- Creators Of The Original Tru-Trac™

Exceptional Value



We've Done Our Homework!
There Is No Better Encoder On
The Market For The Price!

Fast Delivery



- Standard Delivery In 3 To 5 Days
- Next Day No Charge Express
- Expedite Delivery Available

Customer Service



A Helpful Customer Service
Representative Is Available From
8:00 am To 4:30 pm

Contents

- BEPC Product's Overview
- BEPC Small Motor Solutions
- Ultra Rugged 50.8mm Encoders
- Direct Replacement Encoders
- Encoder Solutions
- Typical Usage of Encoders
- Expedite Delivery Information

3 Year Warranty



The Best In The Industry!

BEPC Solutions

Mechanical Interface Problem? BEPC Flex Mount Solution

We Have Got A Bracket For You

At British Encoder Products Company we have the encoder you need with a flexible mounting solution to make your installation a breeze! With bolt hole patterns from 29mm in slotted flex, to 60mm tether arms, BEPC can retrofit most existing flex mounts on the market.

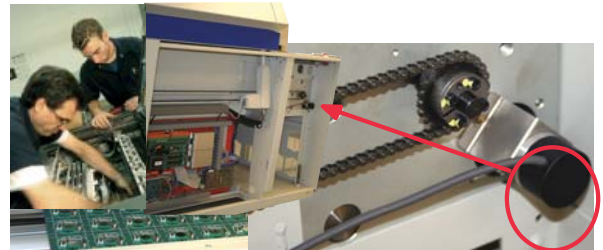

Resolution Requirements? BEPC Has More Options

Large Range Of PPRs With Resolutions Up To 30,000

From the most common resolutions to PPRs up to 30,000 in a 38.1mm encoder, BEPC has the resolutions, commutation, and interpolation available to get your motor/controller performing flawlessly.



High Temperatures/Hot Motors? BEPC Can Take The Heat



Extreme Temperatures To 120^o C

All the small motor encoders shown can take the heat to 100^o C, and the Models 15 and 260 can take the extreme temps of 120^o C~ Now That's HOT HOT HOT!



Delivery Lead Time? BEPC Delivers In 3-5 Days Or Less

Standard Products Or Custom Configuration- BEPC Delivers Fast

Tired of waiting for an encoder to get your production line up and running? BEPC delivers encoders fast. Even custom encoders are often shipped faster than most suppliers standard products. When you need an encoder, let BEPC show you why we continue to lead the industry in fast delivery.

All This With BEPC's Industry Leading Warranty!

British Encoder Products Selection Overview



BRITISH
ENCODER
PRODUCTS COMPANY



Incremental Thru-Bore & Motor Mount Encoders



Ø38.1mm

Models 15T & 15H

- Resolutions to 10,000 PPR
- Up to 12 Pole Commutation Available
- Bore Sizes to 0.375", or 10 mm
- Operating Temps from -40° to +120° C
- Sealing Up to IP64



Ø38.1mm

Model 755A

- Resolutions to 30,000 PPR
- Bore Sizes to 0.750", or 14 mm
- A Variety of Flexible Mounting Brackets
- Operating Temps from -40° to +100° C
- Frequencies to 1 MHz



Ø50.8mm

Model 121

- Patented Auto Aligning Modular Encoder
- Up to 12 Pole Commutation Available
- Bore Sizes to 0.625", or 15 mm
- Ideal for higher speed motor applications
- Resolutions to 2540 PPR



Ø50.8mm

Model 260

- Resolutions to 10,000 PPR
- Bore Sizes to 0.625", or 15 mm
- A Variety of Flexible Mounting Brackets
- Operating Temps from -40° to +120° C
- Sealing Up to IP64



Ø63.5mm

Model 25T

- Replaces 2.0" to 3.5" Encoders
- Resolutions to 10,000 CPR
- Bore Sizes to 1.125", or 28 mm
- Versatile Flexible Mounting Options
- Operating Temps from -20° to +105° C



Ø63.5mm

Models 760

- Resolutions to 10,000 PPR
- Up to 12 Pole Commutation Available
- Bore Sizes to 0.375", or 15 mm
- Operating Temps from 0° to +100° C
- Sealing Up to IP64



Ø110mm

Models 775 & 776

- Slim Profile - to 1.36" Thru-Bores
- Resolutions to 4096 PPR
- Bore Sizes to 1.875", or 43 mm
- Large Selection of Connector Options
- Operating Temps from 0° to +100° C



Ø165mm

Model 770

- Fits NEMA Frame Size 56C Thru 184C
- Resolutions to 4096 PPR
- Bore Sizes to 1.00", or 24 mm
- Large Selection of Connector Options
- Operating Temps from 0° to +100° C



Model 755A NEMA

- NEMA 23 or 34 Motor Mount with Coupling
- Resolutions to 30,000 PPR
- Frequencies to 1 MHz
- Coupling Sizes to 0.375", or 6 mm
- Operating Temps from -40° to +100° C



Ø50.8mm

Model 702 Motor Mount

- 50.8mm Ultra-rugged, Compact Encoder
- Resolutions to 30,000 PPR
- Frequencies to 1 MHz
- Coupling Sizes to 0.500"
- Operating Temps from 0° to +100° C

Stainless Steel Encoders



Ø165mm

Model 865T

- Fits NEMA Frame Size 56C Thru 184C Motors
- Slim 1" Profile Housing in 316 Stainless Steel
- Resolutions to 4096 PPR
- Bore Sizes to 1.00", or 24 mm
- Sealing Up to IP66 with Optional Cover



Ø50.8mm

Model 802S

- 50.8mm Industrial 316 Stainless Steel Housing
- 36 Kg. Max. Radial and Axial Load
- Resolutions to 30,000 PPR
- Shaft Sizes to 0.375", or 10 mm
- Sealing Up to IP66



Ø58 mm

Model 858S

- 58 mm Industrial 316 Stainless Steel Housing
- 36 Kg. Max. Radial and Axial Load
- Resolutions to 30,000 PPR
- Clamping or Synchro Flange Options
- Sealing Up to IP66

Linear Solutions Encoders



Model LCE

- Low Cost Linear Solution
- Imperial and Metric Options
- Sealing up to IP65
- Up to 1.27M or 50 Inches Full Stroke Length



Model TR1

- Integrated Encoder and Measuring Wheel
- Spring Loaded Torsion Arm Adjusts Wheel Pressure for Multi Surfaces: Easy Installation
- Resolutions to 10,000 PPR
- Sealing Up to IP66



Model TR3

- Integrated Heavy Duty Encoder and Measuring Wheel
- Easy Installs in a Vertical, Horizontal or Upside Down Orientation
- Resolutions to 10,000 PPR
- Single or Dual Wheel
- Sealing Up to IP66

Accessories



RX/TXD

- Din Rail Mountable
- Level Changes to 5V, 12V or Vcc
- Resolutions to 30,000 PPR
- Signal Conditioning
- 2 or 3 Way Splitter
- Encoder Tester



Measuring Wheels

- Rubber, Urethane or Knurled
- Sizes up to 500mm Dia
- Custom Bore Options



Cables

- 4 Pin up to 19 Pin
- MS Style, M12 EuroFast, 9-Pin "D" Style
- Cable Length Options



Couplings

- Bore Sizes Up to 12mm Bore
- Magnetic And Flexible Options



Flanges, Brackets and Misc Items

- Flanges and Brackets
- Flex Mount Kits
- Servo Clamps
- Protective Covers
- C-Face Gasket Kits



Power Supply Unit

- 5V, 12V or 24 Vcc
- LED Indicators
- Screw Type Terminals for AWG 24 to 14
- Shock Proof Housing

British Encoder Products Selection Overview



**BRITISH
ENCODER**
PRODUCTS COMPANY



Incremental Shaft Encoders



57.15mm

- Models 711/716 & Cube Housings**
- The Original Cube Encoders
 - Single Channel or Quadrature
 - Versatile Heavy Duty Housing Styles
 - Resolutions up to 10,000 PPR
 - Single and Double Shaft Options



Ø38.1mm

- Model 15S**
- Resolutions to 10,000 PPR
 - Up to 12 Pole Commutation Available
 - Wide Variety of Mounting Options
 - Operating Temps from -40° to +120° C
 - Sealing up to IP64



Ø38.1mm

- Model 755RG & 755 Lid Accessories**
- Resolutions up to 30,000 PPR
 - Frequencies to 1MHz
 - Variety of Servo and Flange Mounts
 - Available with In-Line M12 Connectors
 - Operating Temps from -40° to +100° C



Ø50.8mm

- Model 702**
- Resolutions to 30,000 PPR
 - 35 Kg Max Radial and Axial Load
 - Shaft Sizes up to 0.375" or 10mm
 - Operating Temps from 0° to +100° C
 - Sealing Up to IP67



Ø63.5mm

- Model 725**
- Industrial Isolated Flex Housing Available
 - Resolutions to 30,000 PPR
 - Frequencies Up to 1 MHz
 - Sealing Up To IP67
 - Operating Temps from 0° to +100° C



Ø115mm

- Models 744 "444" Tacho Style**
- Standard "444" Style, 115mm Dia
 - Up to 30,000 PPR
 - Choice of Shaft Sizes
 - IP64 Sealing Available



Ø90mm

- Models 745 Heavy Duty**
- European 90/80/40mm Configuration
 - Resolutions to 30,000 PPR
 - Hohner 3000/4000 Direct Replacement
 - IP64 Sealing Available



Ø58mm

- Model 758**
- 36Kg Max Radial and Axial Load
 - Resolutions up to 30,000 PPR
 - Clamping or Synchro Flange Options
 - Operating Temps from 0° to +100° C
 - Sealing Up to IP66



Ø90mm

- Models 7RP Extra Heavy Duty**
- Extra Heavy Duty Mechanical Assembly
 - Single or Double Ended Shaft
 - Reversible Face Fixing Option
 - Incorporates Opto-ASIC Technology



Ø68mm

- Models 86A Extra Heavy Duty**
- Standard 68mm Dia Package
 - Resolutions to 30,000 PPR
 - Incorporates Opto-ASIC Technology
 - Square Flange Mounting
 - IP65 Double "O" Ring Selaed



Ø90mm

- Model 86F Extra Heavy Duty**
- Transverse Slotted Shaft
 - Up to 3000 PPR
 - Incorporates Opto-ASIC Technology
 - 90mm Round Flange with 3 x 4.5mm Dia Holes at 120 Degrees apart on a 82mm PCD
 - Double "O" Ring Sealed

Absolute Encoders



Ø36mm

- Model SA36H Single-Turn**
- Standard Size 36mm Package
 - Double Magnetic Technology
 - Up to 14 Bits of Single Turn Resolution
 - SSI and CANopen Communications
 - Hollow Shaft and Flex Mounting



Ø36mm

- Model SA36S Single-Turn**
- Standard Size 36mm Package
 - Double Magnetic Technology
 - Up to 14 Bits of Single Turn Resolution
 - SSI and CANopen Communications
 - 6mm or 0.250" Shaft & Servo Mounting



Ø36mm

- Model MA36H Multi-Turn**
- Standard Size 36mm Package
 - Double Magnetic Technology
 - Multiturn Absolute Encoder (14 Bit/40 Bit)
 - SSI and CANopen Communications
 - Hollow Shaft and Flex Mounting



Ø36mm

- Model MA36S Multi-Turn**
- Standard Size 36mm Package
 - Double Magnetic Technology
 - Multiturn Absolute Encoder (14 Bit/40 Bit)
 - SSI and CANopen Communications
 - 6mm or 0.250" Shaft & Servo Mounting



Ø63.5mm

- Model MA63S Multi-Turn**
- Standard Size 25 Package 63.50mm Dia
 - Double Magnetic Technology
 - Multiturn Absolute Encoder (14 Bit/40 Bit)
 - SSI and CANopen Communications
 - Servo & Flange Mounting



Ø63.5mm

- Models 925**
- Industrial Housed 63.5mm Single Turn Absolute Encoder
 - Gray, Natural Binary, and Excess Gray Code
 - Shaft Sizes to 0.375" or 10mm
 - Flange and Servo Mounts
 - Sealing Up to IP66



Ø58mm

- Models 958**
- European Size 58mm
 - Gray, Natural Binary, and Excess Gray Code
 - Shaft Sizes to 0.375" or 10mm
 - Clamping or Synchro Flange Options
 - Sealing Up to IP66



Ø50.8mm

- Model 960**
- Low Profile - 39.37mm Single Turn Absolute
 - Opto-ASIC Circuitry in an All Metal Housing
 - Resolutions Up to 11 Bits
 - Bore Sizes to 0.375" or 10mm
 - A Variety of Flexible Mounting Brackets

British Encoder Products Has The Solution!



Replacing your encoder has never been simpler.

Model 15S



Our Model 15S has more mounting face options than any other 38mm shaft encoder. A variety of bosses and bolt hole patterns will provide cross-reference adaptability like no other encoder.

Model 15T



Model 15H



Models 15T and 15H are the superior choice for your servo or stepper motor application. Endurance in High Temperatures, High Resolution Performance, Commutation, and Flexible Mounting Options make the 15T/H an unbeatable encoder.

Cross References:

The Model 15 can be crossed to many encoders- this is NOT a complete list. Please contact Customer Service for additional offerings and to ensure complete and accurate cross-referencing.

Competitors Model	15S Mounting Face
Automation Dir TRDS	M1
DRC 23	M4
DRC 77L	M4
DRC M2	M3, M4
Dynapar E14	M5
Dynapar E23	M6
Nemicon OEW	M7
Nemicon OVW	M1
Renco RS15	M6
Sumtak IRS3	M1
Tamagawa OIS38	M1
Tekel TK-15	M6
Omron E6B2	M8
Sumtak LBL	M9

Competitors Model	15T/H Flex Mount PCD
DRC 730	FF
DRC 731	FF
DRC H15	SF
DRC T23	FF
Dynapar M14	SC
Dynapar M15	SF
Dynapar M21	SF
Dynapar F14	SB, SF
Renco RHS15	SF
Renco RCM15	SC
Sumtak IRH3	SD
Sumtak IRT3	SD
Sumtak LBK/LDA	FF, SF
Turck 8.3720	SF

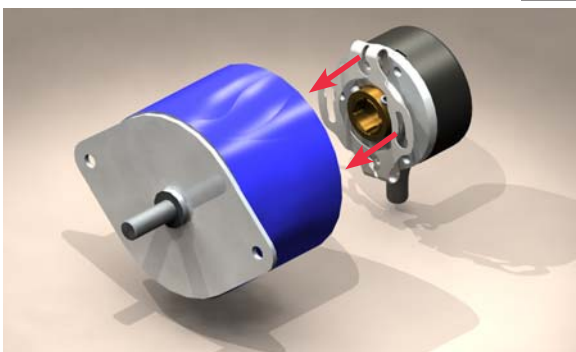

On Smaller Motors Such As Steppers, Servos, and Gearhead Motors, Encoders Are Positioned On The Exit End Of Motor.

Ultra Rugged 50.80mm Encoder & Related Products



Quick Specs

- Rugged Industrial Encoder
- 50.80mm x 50.80mm Housing
- PPR to 30,000
- Many Output Types
- RPM to 8000
- Sealing to IP66
- High Temperature Option

Mounting Options

The 702 Motor Mount comes with coupling and available with a Bossed Hub to attach directly to fast revving motors.

The 702 Shaft has many different servo mounts and mounting flanges available and able to handle heavy loads.

Other Related Products



The Model 802S is an industry standard Size 20 (50.80mm diameter) encoder housed in a heavy duty 316 stainless steel package. It's specifically designed for harsh factory and plant floor environments. A variety of flange and servo mounting styles, make it easy to use in a broad range of applications.



Model 725 Size 25 optical shaft encoder is specifically designed for the challenges of an industrial environment. But don't let its tough, industrial package fool you; it still has the performance to reach resolutions up to 30,000 pulses per revolution.



The Model 858S European Size 58 is a heavy duty, extremely rugged, reliable encoder, in a 316 stainless steel package. Its compact design is well suited for harsh factory and plant floor environments, calling for a metric solution.



The Best Choice

- A 3-Year Satisfaction Guaranteed Warranty
- Encoder Products Company has Specialised in Building Only Durable, Dependable Encoders for More Than 40 Years
- Superior Customer Service
- More Configurations Than Any Other Encoder Manufacturer
- Expert Cross Reference Service
- Next Day Expedite Delivery Available

It Just Makes Sense.

Replace Costly OEM Encoders Fast and Easy

You likely have motors from multiple manufacturers in your plant. And, for all those motors, you've got just as many different encoder models and brands to manage.

They all have different lead times from different vendors and probably cost a bundle.

Want to know a secret?

Most of those encoders can be replaced with just a few configurations of BEPC's Encoders - for example the Model 25T. This versatile high-performance encoder is at the heart of our Direct Motor Replacement (DMR) line.

Our DMR's fit the feedback needs of most common industrial motors, with more configurations being added regularly.

With DMRs you can replace the encoders in your plant with one source, getting equivalent encoders faster and for less.

It's a sensible choice.



Direct Replacement Encoders

Consolidate vendors with versatile DMRs

Save on encoder replacements for most major motor brands

Meets or exceeds OEM specifications for performance and fit

Short lead time—as fast as 24 hours

Industry best three year warranty



Encoder Solutions For Packing, Printing, Labelling



Typical Examples of Select Encoder Applications

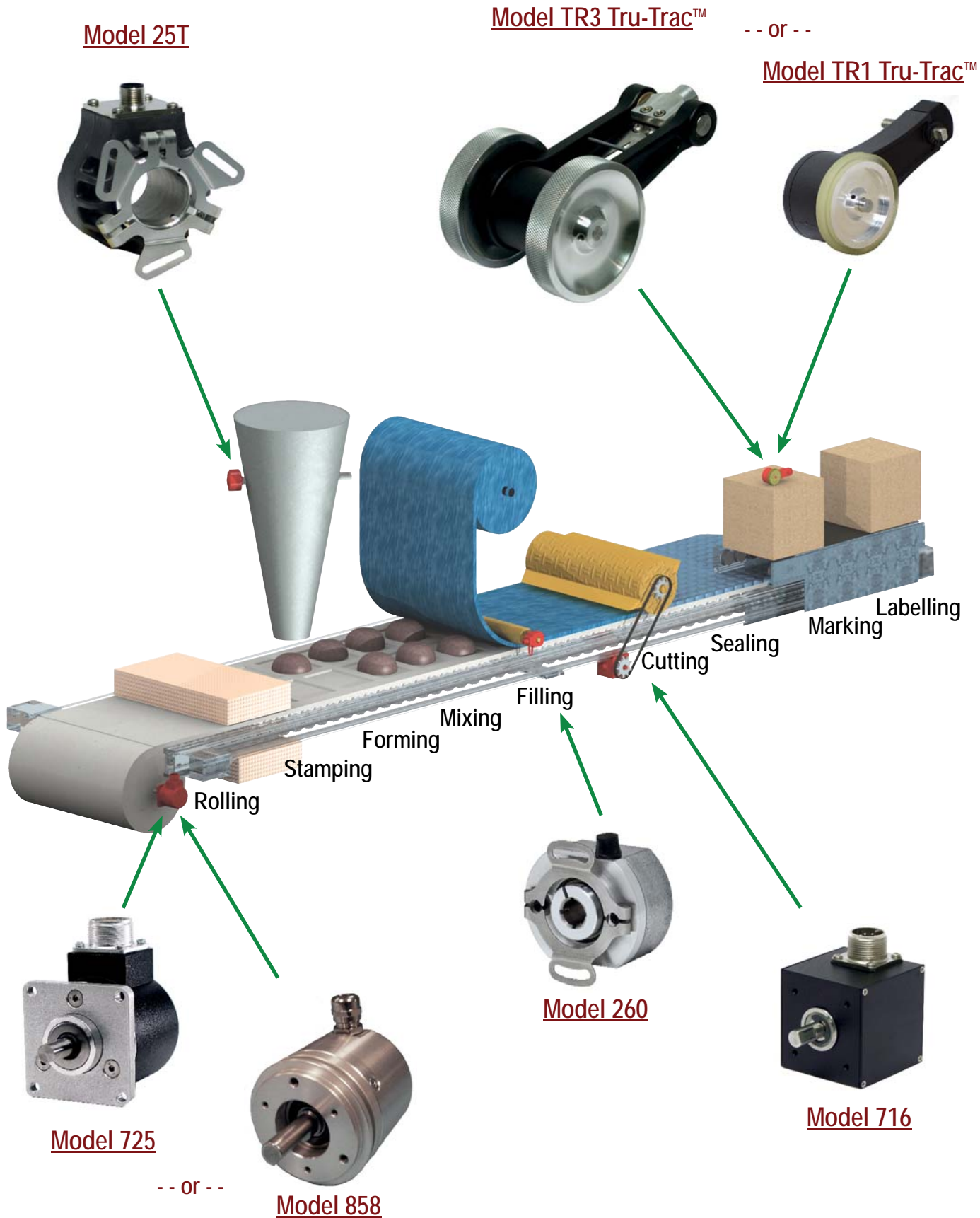

British Encoder Products

Typical Usage



Motor feedback is the most common use for rotary encoders. In this type of application, an encoder is either mounted directly to the motor, or indirectly using a measuring wheel or chain-and-sprocket arrangement. The parameter of interest is primarily the speed of the motor.

Web tensioning is an application in which the encoder is not usually mounted to the drive motor, but to one of the tensioning arm rollers. Any unevenness in the speed of this roller indicates that proper web tension is not being maintained and must be adjusted. The rotating speed of the tensioning roller is fed back to the controller, which then adjusts the drive motor so that web material is kept at an even tension.

Cut-to-Length is a very practical application of an encoder combined with simple mathematics. If, for example, a system were to be designed with a roller that is exactly 200mm in circumference, the roller would feed 200mm of material for every revolution of the roller. An encoder mounted to the roller would reflect this situation and could tell a controller how much material had been fed through the roller. The resolution of the encoder would also directly reflect the accuracy of the cut. In the above example, 100 PPR would yield cuts to an 2mm accuracy.

Elevators are just one example where encoders can perform a dual role. They can determine the position of the elevator through a mathematical calculation similar to the above, and they can determine the speed of travel of the elevator.

Registration Mark Timing uses encoders to determine the position of a unit relative to a known point, and then to determine the unit's speed relative to that mark. Radar antenna rotation is a good example of this type of application.

In **Backstop Gauging** the encoder is used to make sure that the unit, typically a machine tool, does not exceed a preset position or direction of travel. Very often, this is combined with a determination of the speed of travel of the table, tool head, or similar component. A typical filling application is just one example where Table Positioning is critical since the item being filled must arrive at filling tube at the same time the fluid control is turned on.

Conveying is another common industry where encoders are widely used. They may be attached to the motor, to intermediate axle shafts, or to both. Encoders are an especially effective feedback device where

the positioning and/or speed of multi-element conveying systems must be carefully coordinated.

Spooling (sometimes referred to as Level Wind) is another application where encoders can prove invaluable. Not only is it necessary that the speed of the supply and take-up reels be kept in proper relation to each other, but the amount of material being spooled must also often be tracked.

Electronics is just one industry that widely uses encoders in Pick and Place applica-

tions. Here many of the capabilities of encoders (rate, position, speed, velocity) can often be found combined in a single system.

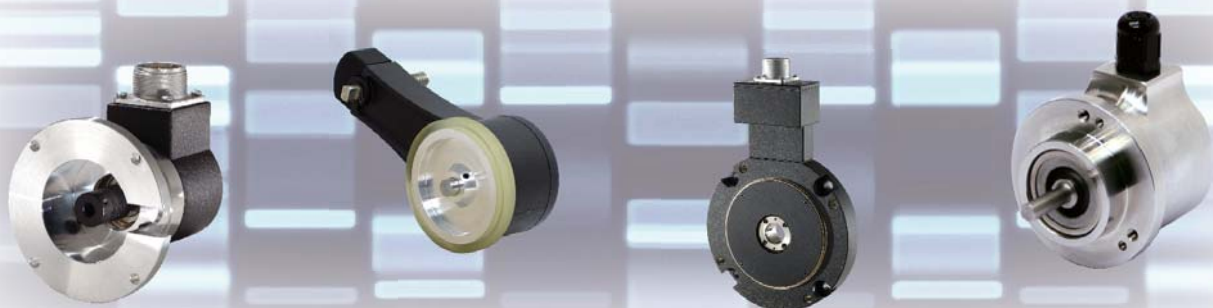
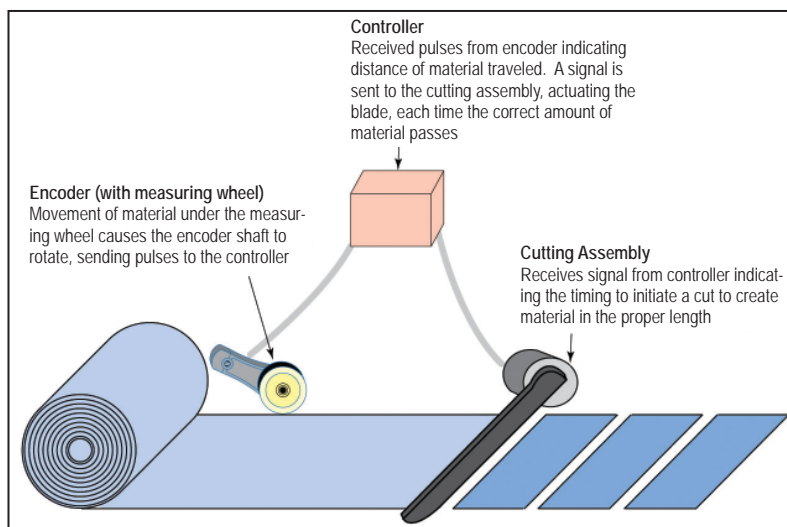

British Encoder Products Expedite and Express Delivery.



On occasion, you may find that your time requirement for an encoder exceeds our industry-leading standard lead delivery terms. Fortunately, British Encoder Products Company is committed to doing everything in our power to ensure our products arrive in the shortest time possible. We have developed the following Expedite options for your benefit.

See COMMENTS below for important considerations before placing your order.

Options	Service	Cut Off (GMT)	Cost
Expedite	24 Hour Same Day Ex-Works	09.30	£60.00
Express	Ships Within 48 Hours Ex-Works	13.00	£40.00

Expedite :- 24 Hour build = £60.00 Ex-Works - providing we receive your order before 09:30.

Express :- 48 Hour build = £40.00 Ex-Works - providing we receive your order before 13.00.

Provisions

- 1) The above charges apply to 1 Unit orders only, and any additional encoders will incur an additional £50 charge per unit for Expedite and £25 charge per unit for Express.
- 2) **Expedite availability is limited** and is provided on a first-come-first-served basis. Earlier is better.
- 3) **Orders must be received via FAX** at +44(0)1978262101 or **EMAIL** at sales@encoder.co.uk by the stated cut-off time.
- 4) **Certain configurations are not eligible** for same day Expedite due to minimum build time. These include disc resolutions above 3000 PPR, certain SPEC offerings and other products. These configurations may be available on the Express 24/48 Hours Service. Always confirm at the time of order.
- 5) **Always confirm Expedite** requests at the time of order with BEPc customer service.
- 6) **Hours of operation: Monday to Friday 08:00 to 16.30 GMT**



Encoder solutions for a world in motion



World Headquarters Americas Division

Encoder Products Company
464276 Highway 95
PO Box 249
Sagle, Idaho 83860
USA

ISO 9001:2008 Certified
RoHS/REACH/WEEE Compliance

Phone: 800-366-5412, 208-263-8541
Fax: 208-263-0541
E-mail: sales@encoder.com
Website: www.encoder.com

European Manufacturing Division

British Encoder Products Company
Whitegate Industrial Estate, Unit 33
Wrexham, Clwyd
Wales LL13 8UG
United Kingdom

Phone: +44.1978.262100
Fax: +44.1978.262101
E-mail: sales@encoder.co.uk
Website: www.encoder.co.uk

Asia Division

Zhuhai Precision Encoder Co., LTD
5, Jian Ye 1 Road, 5/F West
Ji Da District
Zhuhai City 519015
People's Republic of China

Phone: +86.756.3363470
Fax: +86.756.3363573
E-mail: EPC-Asia@163.com
Website: www.asiaencoder.com

All Locations Provide~

Superior Design



Exceptional Value



Fast Delivery

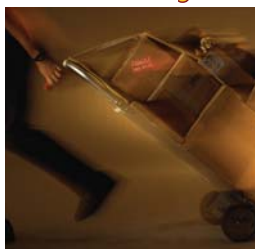

Customer Service



3 Year Warranty



www.encoder.co.uk

Email: sales@encoder.co.uk / Tel: +44 (0)1978 262100